

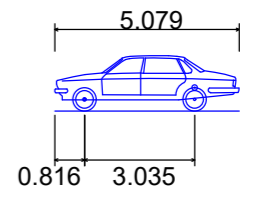

LEGEND:

- SITE BOUNDARY ———
- RIPARIAN CORRIDOR - - - - -



Large Car
 Overall Length 5.079m
 Overall Width 1.872m
 Overall Body Height 1.525m
 Min Body Ground Clearance 0.310m
 Max Track Width 1.831m
 Lock-to-lock time 4.00s
 Curb to Curb Turning Radius 5.900m

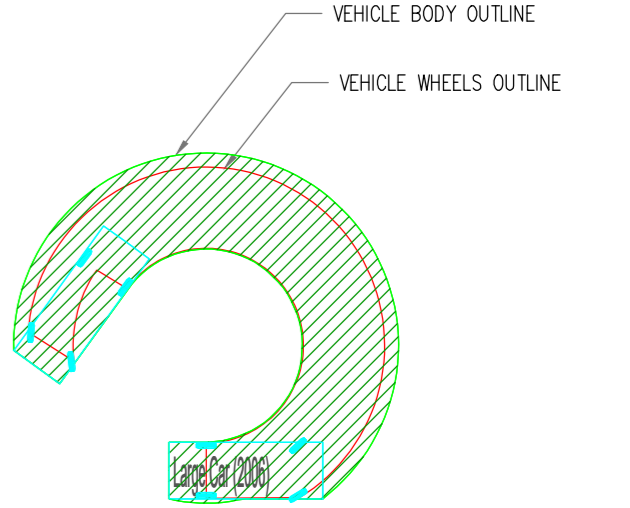

SWEPT PATH PLAN.

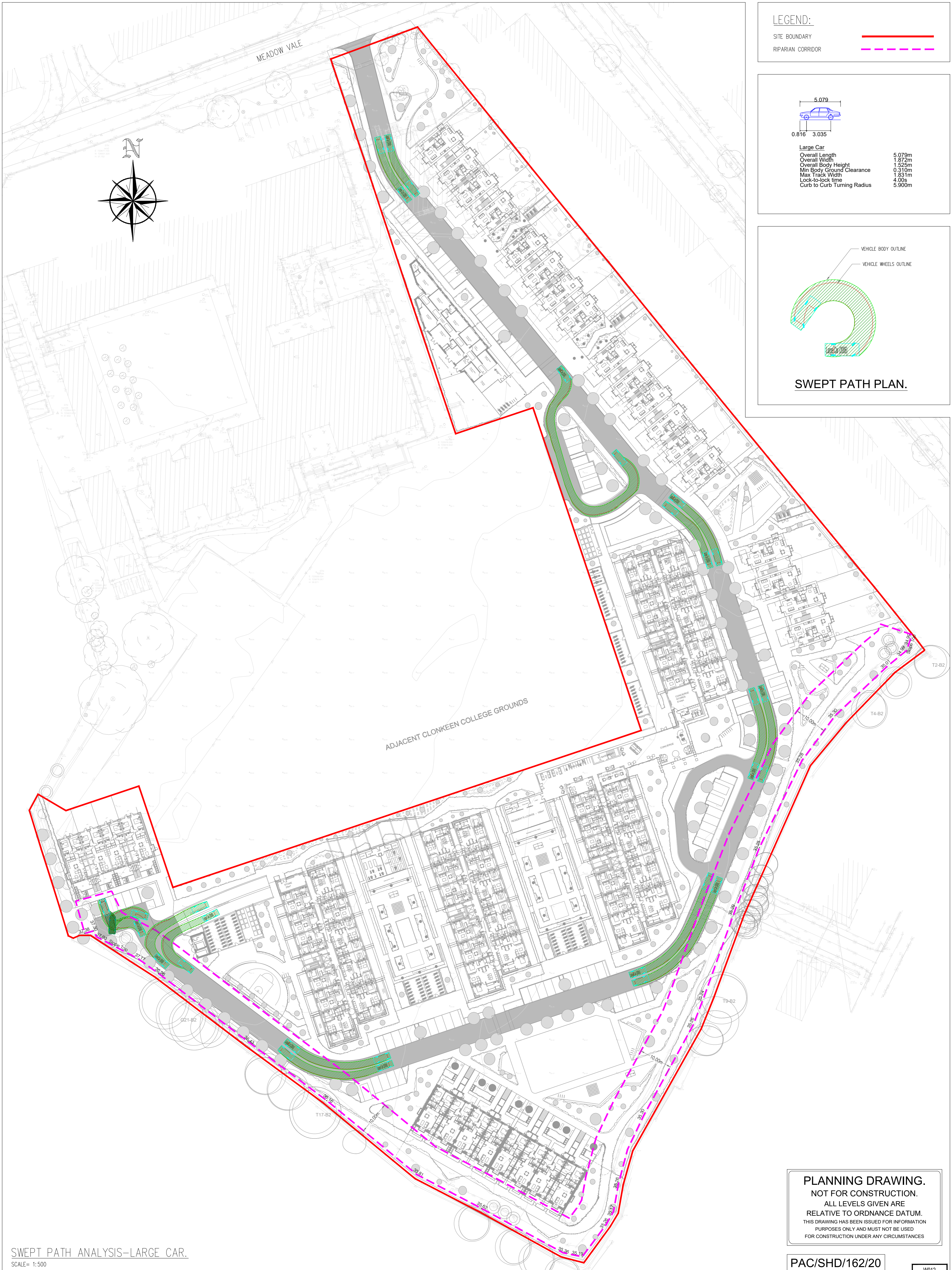

SWEPT PATH ANALYSIS—LARGE CAR.
 SCALE= 1:500

PLANNING DRAWING.
 NOT FOR CONSTRUCTION.
 ALL LEVELS GIVEN ARE
 RELATIVE TO ORDNANCE DATUM.
 THIS DRAWING HAS BEEN ISSUED FOR INFORMATION
 PURPOSES ONLY AND MUST NOT BE USED
 FOR CONSTRUCTION UNDER ANY CIRCUMSTANCES

PAC/SHD/162/20 W012

- NOTES**
- For setting out refer to Architect's drawings.
 - This drawing to be read in conjunction with all other Architectural and Engineering drawings and all other relevant drawings and Specifications.
 - DO NOT SCALE THIS DRAWING. Use figured dimensions only.
 - No part of this document may be reproduced or transmitted in any form or stored in any retrieval system of any nature without the written permission as copyright holder except as agreed for use on the project for which the document was originally issued.
 - Ordnance Survey Ireland Licence Number EN 0074021

Rev. No.	Date	REVISION NOTE	Drn. By	Chkd. By
P1	13.10.2020	ARCHITECTS LAYOUT REVISED	JS	OS
P2	15.06.2021	ARCHITECTS LAYOUT REVISED	JS	OS

Architect	Scott Tallon Walker			
Project	Proposed Development at Clonkeen Road			
Title	Swept Path Analysis. Large Car.			
Dwg. No.	W012-CSC-ZZ-XX-DR-C-0013			
Date	Drn. by	Chkd. by	Aprvd. by	Scale
02.06.2020	JS	NB	OS	1:500 @A1
Revision	P2			

CS Consulting Group
 DUBLIN | LONDON | LIMERICK

Head Office
 19-22 Dame Street, Dublin 2.
 T: +353 (0)1 5480863 F: +353 (0)1 9011355
 E: info@csconsulting.ie
 W: www.csconsulting.ie

Quality
 Environment
 Energy
 Health & Safety

I.S. EN ISO 9001:2008
 I.S. EN ISO 14001:2004
 I.S. EN ISO 50001:2011
 OHSAS 18001:2007